

The Onyx Isolator Ring

Out-Performs Conventional Isolator Rings And Standard Diaphragm Seals

Obtaining accurate pressure readings on slurry lines is difficult because slurries, abrasives and solids clog pressure elements such as gauges, switches and transmitters.

Isolator rings consist of a rubber "inner tube" captured in a steel ring. The assembly is installed between flanges in the process pipe. Clear instrument oil behind the rubber membrane transmits pressure to the gauge. The inside diameter of the ring assembly matches the adjacent pipe so the ring is continually cleaned by the motion of the process fluid.

A common problem with this type of isolator ring is that any air inside the instrument will compress when pressurized. This stretches the rubber membrane, causing accuracy to degrade or the instrument to malfunction. (An air bubble as small as a pea can make an isolator non-functional.) To counter this obstacle, isolator ring manufacturers use a vacuum pump to evacuate the air from the isolator before injecting the instrument fluid. To remove the gauge for replacement or calibration, the entire ring and gauge assembly must be removed from the process pipe and the gauge and ring have to be drained, evacuated and refilled. This causes considerable downtime and expense.

Some manufacturers try to circumvent this problem by adding a valve to the ring assembly. This holds the fluid in the ring, but attempting to fill the gauge by turning it upside down and pouring fluid into it traps an air pocket at the tip of the Bourdon tube. Also, attempting to remount the gauge by covering the connection with your finger while turning it upright and screwing it into the isolator is rarely successful.

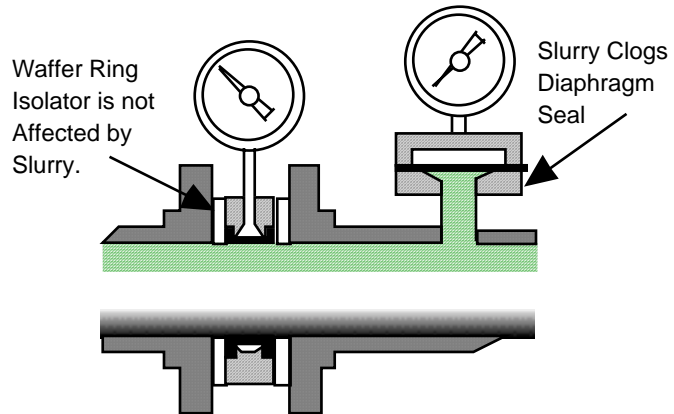

Standard diaphragm seals - drilled or welded at a point on the pipeline - provide a temporary solution, but are vulnerable to plugging and stop working when slurry solidifies in the seal chamber.

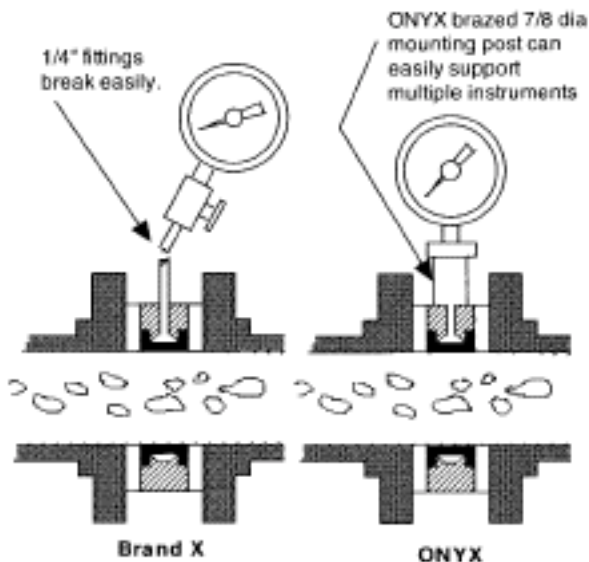

Robust 0.87" dia. mounting post resists breakage. Provides sturdy mounting for heavy gauges and instruments. Up to three gauges, pressure switches and transmitters can be combined on one isolator without additional support.

The Onyx Isolator Ring: The Solid Solution For Solving Your Pressure Measurement Problems

The Onyx Isolator Ring provides a practical, cost-effective method for obtaining accurate pressure measurements on slurries, abrasives and hard-to-handle materials.

The Onyx Isolator Ring's new patented design solves the problems associated with isolator rings on the market today.

The Onyx Isolator Ring is vacuum-filled at the factory with high-viscosity silicone fluid; then permanently-sealed with Onyx's Revolutionary "Module-Seal".

With the Onyx Isolator Ring, there is no fill port anywhere on the assembly: gauges, switches and transmitters are supplied separately, are pre-filled with Onyx's special fitting attached.

Select any combination of isolator ring and gauge and simply snap them together.

With the Onyx Isolator Ring, you are guaranteed hassle-free operation and added protection for your sensitive indication instrumentation.

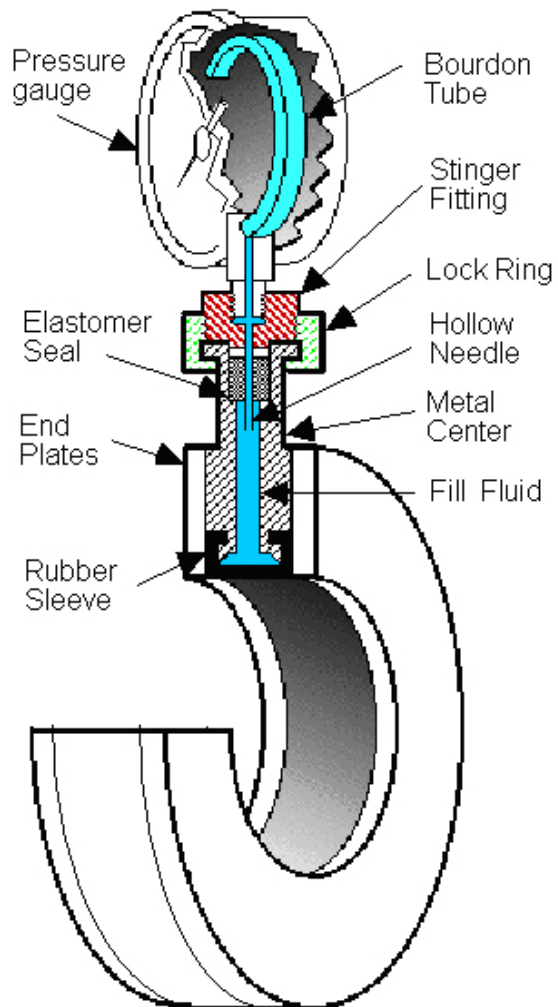
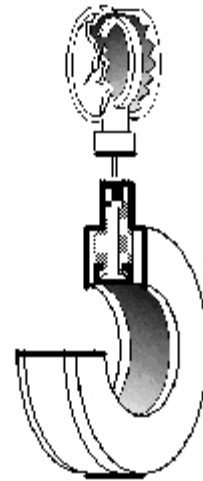

Practical Applications Of The Onyx Isolator Ring

The Onyx Isolator Ring can be used in a variety of industries such as chemical, food & beverage, mining, pulp & paper and waste water treatment. Typical applications include:

- Pressure measurement of slurries, corrosives and difficult fluids.
- Tank Level Indication.
- Monitor pressure on long distance pipe lines to detect line breaks.
- Monitor pressure drop across a filter or pump using
- Measure the output pressure of a pump.
- Send a signal to stop a pump or open a by-pass valve.

Proven Benefits Of The Onyx Isolator Ring

- Gauges can be removed or replaced without interrupting process
- Gauges can be replaced without vacuum filling
- No tools required to change pressure instrument (simply remove and replace by turning the lock ring)
- No snubber required (needle functions as built-in snubber)
- Improved safety (process liquid cannot escape if gauge is removed, even if process pipe is under pressure)
- High accuracy (because air can never get into the system)
- No isolation valve required
- Gauges can be rotated by hand to face any direction
- Isolation rings and gauges can be stocked separately (combine as needed on the spot)

Center Section:	<ul style="list-style-type: none"> • Carbon Steel • 316 Stainless Steel • Carpenter-20
End Plates:	<ul style="list-style-type: none"> • Acetal • 316 Stainless Steel • Teflon • Kynar • Titanium • Carpenter-20
Elastomer:	<ul style="list-style-type: none"> • Neoprene -20°F --> 220°F • Nitrile (Buna-N) -20°F --> 180°F • EPDM (Nordel) -20°F --> 300°F (Avail with optional Teflon coating) • Fluoroelastomer (Viton) -20°F --> 375°F (Avail with optional Teflon coating) • Chlorosulfonated Polyethylene (Hypalon) -20°F --> 250°F
Fill fluid:	<ul style="list-style-type: none"> • Silicone fluid -40°F --> 400°F • Food Grade Silicone (Optional) -20°F --> 400°F

Dimensions

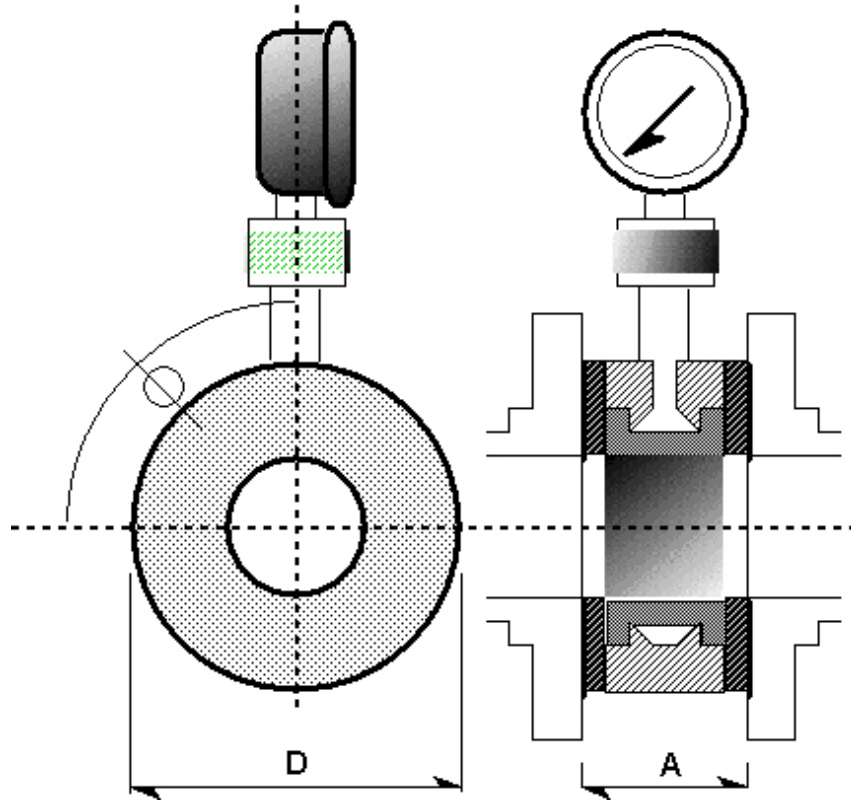

Standard gauge:

- Size: 100 mm dia.
- Sealed stainless steel case with crimped ring.
- Bronze tube and socket.
- Liquid filled.
- ANSI grade B accuracy.
- +30°F --> 150°F ambient temp range.
- Available ranges from -30" Hg / 0 / +15 Compound to +1,000 psi.

Size	A	D dia		Size	A	D dia
1	1.87	2.50		8	2.25	10.87
1.5		3.25		10	2.81	13.25
2		4.00		12	3.12	16
2.5		4.75		14		17.62
3		5.25		16		20
4	2.12	6.75		18		21.50
5	2.25	7.62		20		23.75
6		8.62		24		28.12