

ONYX VALVE CO PRESSURE ISOLATOR RING

INSTALLATION AND MAINTENANCE INSTRUCTIONS

PRINCIPLE OF OPERATION:

Obtaining accurate pressure readings on slurry lines is difficult because slurries, abrasives and solids clog pressure elements such as gauges, switches and transmitters.

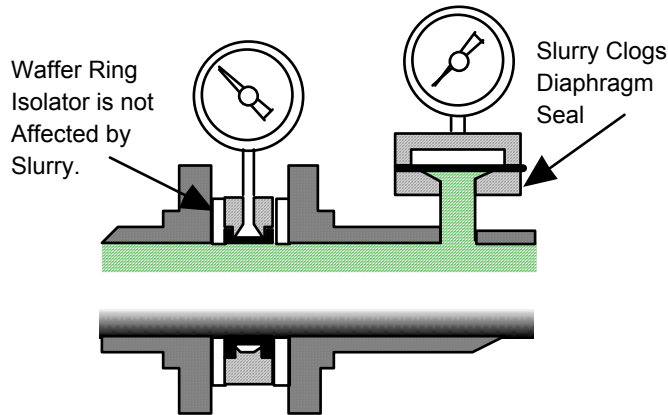

Isolator rings consist of a rubber "inner tube" captured in a steel ring. The assembly is installed between flanges in the process pipe. Clear instrument oil behind the rubber membrane transmits pressure to the gauge. The inside diameter of the ring assembly matches the adjacent pipe so the ring is continually cleaned by the motion of the process fluid.

The Onyx Isolator is vacuum filled at the factory with high viscosity silicone fluid. (Other fluids available on special order.)

After vacuum filling, the Isolator Ring is permanently sealed with our patented 'Module Seal'. The Module Seal enables the user to remove or replace gauges and other pressure instruments while the Isolator Ring remains in the process pipe without having to vacuum fill the ring.

MAINTENANCE:

The Onyx Isolator Ring requires little maintenance.



ONYX VALVE

835 Industrial Hwy Cinnaminson NJ 08077

Ph: 856-829-2888 Fax: 856-829-3080

Web: www.onyxvalve.com

Email: Info@onyxvalve.com

Tighten Modul Seal
to eliminate
weeping

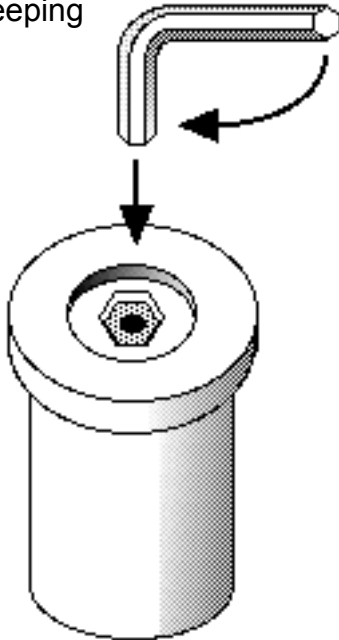

The Isolator is usually supplied with instrumentation such as gauges, transducers, and pressure switches; refer to specific manufacturer's literature concerning maintenance for these accessories.

If you detect instrument oil weeping from under the Lock Ring, the Module Seal may require minor adjustment.

(If you do not detect any leakage or weeping in the area of the Module Seal, leave it be.)

To adjust the Module Seal:

- a) Loosen the lock ring and carefully remove the pressure measuring instruments.
- b) Insert a 0.250 inch allen key into the Module Seal Set Screw and turn clockwise 1/8 revolution.
- c) Reinstall the pressure measuring instruments and tighten Lock Ring.

Turning the Set Screw clockwise eliminates weeping but makes the fit around the needle tighter.

If the Module Seal is too tight to reinstall the pressure measuring instrument, do not force the needle in or risk bending or breaking the needle. Instead, loosen the Set Screw until the needle can be inserted easily. If fluid weeping persists, it may be necessary to tighten the Set Screw further. When tightening the Set Screw, try 1/8 turn at a time.

PRESSURE RATING:

The Onyx Pressure isolator is rated for operation up to 1,000 psi.

STORAGE:

Correct storage extends service life. Rubber is perishable. Ideal storage conditions are 50°F / 60% relative humidity. We recommend the following precautions for Isolators and spare parts stored for any length of time prior to installation.

1. Keep Isolators cool. They can be stored in an unheated area, but allow maximum ventilation in storage areas subject to high ambient temperatures. Trailers and storage sheds become incredibly hot during summer months. Avoid such locations.
2. Avoid sunlight. Ultra-violet light deteriorates rubber. Leave the Isolator in its box.
3. Avoid ozone. DO NOT STORE Isolator near active electrical equipment.
4. The Isolator may be supplied with sensitive instrumentation. Refer to specific manufacturer's literature concerning proper storage.

5. Separate instruments may be supplied with a stinger fitting attached. **DO NOT REMOVE RUBBER TIP PROTECTOR FROM THE STINGER FITTING NEEDLE UNTIL ATTACHING THE FITTING TO THE ISOLATOR RING.**

INSTALLATION:

1. Safety Considerations:

- a) Pressure Isolators frequently handle chemically reactive and abrasive fluids; it is reasonable to expect the elastomer sleeve to eventually wear out. Instrument fill fluid must be compatible with the process liquid. Mixing incompatible fluids may cause a violent chemical reaction resulting in equipment damage or personal injury.
 - b) Make certain that instruments such as gauges, pressure switches, etc, have pressure and temperature rating suitable for actual operating conditions. Exceeding manufacturer's design limits may result in equipment damage or personal injury.
 - c) The rubber sleeve elastomer must be compatible with the chemistry and temperature of the process fluid.
 - d) **Do not use this Isolator for oxygen service.**
2. Inspect prior to installation. **DO NOT INSTALL AN ISOLATOR KNOWN TO HAVE BEEN DAMAGED IN SHIPMENT.** The Pressure Isolator should not show any indication of leakage, and rubber sleeve should be free from cuts or punctures.
 3. The Pressure Isolator can be installed in any attitude with flow in either direction. Install in straight pipe run as far from tees and elbows as possible.
 4. Onyx Isolator rings may be installed without pressure instruments attached. This minimizes damage to gauges and sensitive pressure instruments during pipe fitting and construction.
 5. The Pressure Isolator is vacuum filled at the factory to insure high accuracy in operation. **DO NOT DISASSEMBLE UNLESS NECESSARY FOR REPAIRS.**
 6. To install, sandwich the Isolator between two flanges in the process pipe line. Center as carefully as possible. Install gaskets on both sides of Isolator. Insert flange bolts. Tighten flange bolts in criss cross pattern.

OPERATING INSTRUCTIONS:

1. Onyx Isolator Rings and pressure instruments are vacuum filled at the factory. They may be shipped assembled or shipped separately for field assembly.
 - A) Do not disassemble the ring except to replace the rubber membrane.
 - B) **Do not break connections between the stinger fitting and pressure instruments.**
 - C) Do not remove the rubber protector from the stinger needle until you are ready to attach the instrument to the Isolator Ring.

2. To attach a pressure instrument (with a stinger fitting) to the Isolator Ring:

Pressure measuring element and stinger fitting must be pre-assembled and vacuum filled prior to attaching to the Iso Ring!

- A) Instruments can be attached to an Isolator Ring installed in the pipe line while the system is pressurized.
 - B) Hold the pressure instrument and stinger fitting assembly upright above the Isolator Ring.
 - C) Remove the rubber tip protector from the stinger needle (#5D). (Save the rubber tip protector.)
 - D) Gently push the needle (#5D) through the rubber Module Seal (#5) until it hits bottom.
 - E) Thread the coupling ring (#5C) onto the stinger fitting (#5E). **HAND TIGHTEN.**
 - F) Gauges can be rotated to face any direction by loosening the coupling ring, turning the gauge, and re-tightening the ring.
3. To attach instruments which did not come with a stinger fitting, refer to separate instructions on vacuum.

4. To remove pressure instruments from the Isolator Ring:

- A) It is NOT necessary to remove the Isolator Ring from the process pipe.
- B) In order to minimize fluid loss, **reduce process pressure as low as possible before removing gauges or other instruments from the Isolator Ring.**

Turn off pump prior to removing instrument from the Isolator Ring. (The interruption will be brief. Instruments can be removed from the Isolator in about 10 seconds.)

- C) Loosen knurled coupling ring (#5C).
- D) Gently lift the gauge and stinger assembly out of the module seal.
- E) Immediately attach a rubber tip protector to the end of the stinger needle.
- F) Now your process can be re-pressurized without losing fluid from the Isolator Ring.

SLEEVE AND MODULE SEAL REPLACEMENT:

1. Remove Isolator Ring from process line.
2. Remove gauge or auxiliary instrument ass'y (#6,5E).
3. Remove screws, end plate (#4A).
4. Remove end plates (#4).
5. Remove old sleeve (#1).
6. Use a 0.250 inch hex key to remove the seal screw (#5B).
7. Use a packing extractor to remove the old rubber seal (#5).

8. Clean all components thoroughly.
9. Press new rubber seal (#5) into the stem (#5A). Drive all the way to bottom of bore. Replace seal screw (#5). Do not over tighten.
10. Collapse new sleeve (#1), push through housing (#3) and work seal lips into housing grooves.
11. Reinstall end plates (#4).
12. Replace end plate screws (#4A).
13. Connect a separate stinger fitting (#5E), to vacuum filling system, evacuate air from the ring assembly, and refill with fresh instrument fluid. Use Onyx silicone fluid.
14. The Isolator Ring can now be returned to service.

TO ATTACH STINGER FITTING TO INSTRUMENTS:

1. Attach gauge or other instrument to the stinger fitting (#5E).
2. Connect an Onyx Module Seal Adapter to your vacuum filling system.
3. Attach the instrument assembly to the adapter fitting.
4. Evacuate all the air from the instrument, and fill with silicone fluid.
5. Detach the instrument from the filling system. Protect the stinger needle with a rubber tip protector.
6. The instrument can now be attached to an Isolator Ring, or stored for future use.



ONYX VALVE

835 Industrial Hwy Cinnaminson NJ 08077

Ph: 856-829-2888 Fax: 856-829-3080

Web: www.onyxvalve.com

Email: Info@onyxvalve.com

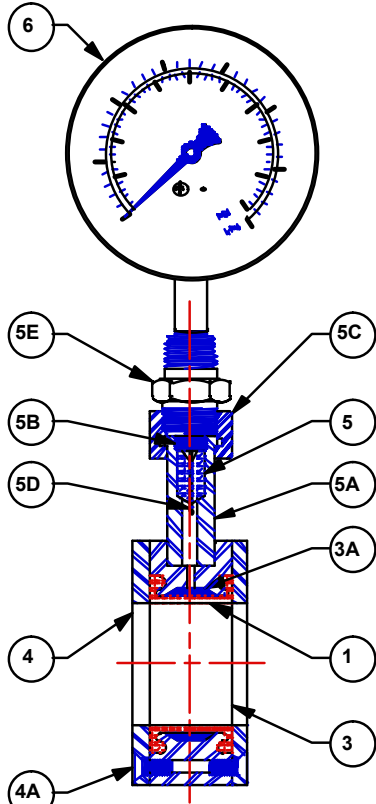

ITEM	DESCRIPTION	REQ'D
1	SLEEVE.....	1
3	CENTER.....	1
3A	SENSING LIQUID, CENTER.....	AS REQ'D
4	END PLATE.....	2
4A	SCREW, END PLATE.....	*
5	SEAL.....	1
5A	TUBE, SEAL.....	1
5B	SET SCREW, SEAL.....	1
5C	COUPLING, SEAL.....	1
5D	NEEDLE, SEAL.....	1
5E	FITTING, SEAL.....	1
6	GAUGE.....	1

* SEE CHART

QUANTITY										
ITEM	1	1-1/2	2	2-1/2	3	4	6	8	10	12
AA	4	4	4	4	6	6	8	8	12	12

REV	DESCRIPTION	BY	DATE	APP'D
	ONYX VALVE			
TITLE: PRESSURE ISOLATOR RING (WAFER STYLE)				
SCALE: NONE	DRAWN: MDM	DATE: 11-1-95		
DESIGNED:	CHKD:	DATE:		
CUSTOMER: STD	APP'D:	DATE:		
P	C-80000	DATE: 1	REV: 1	